

Without BKL

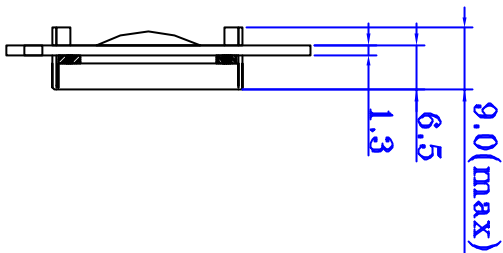

LED BKL

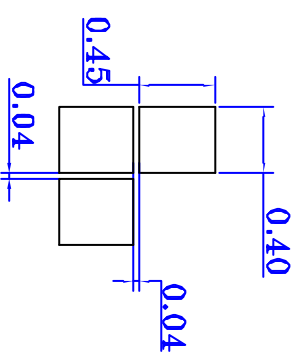
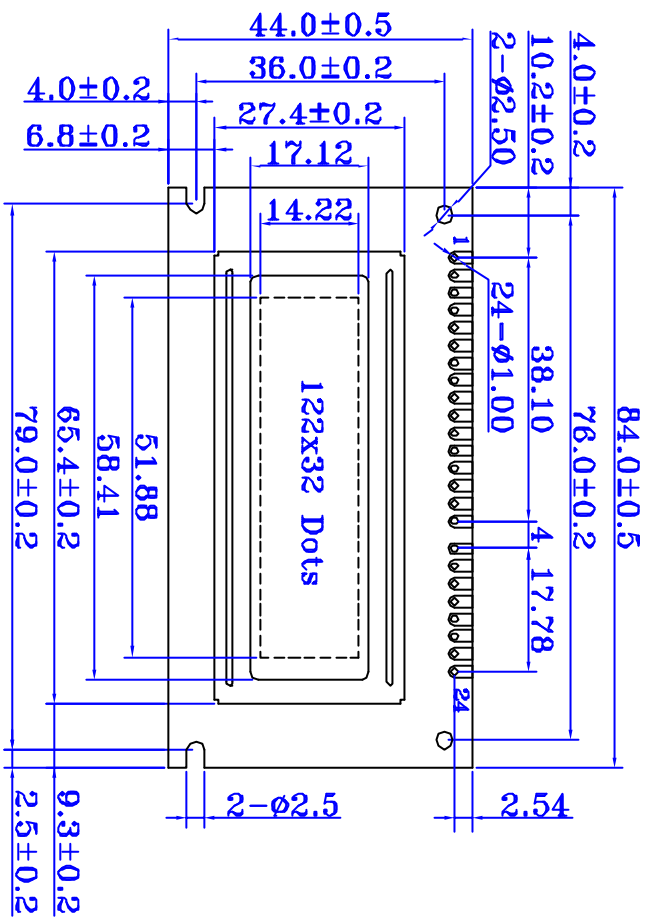
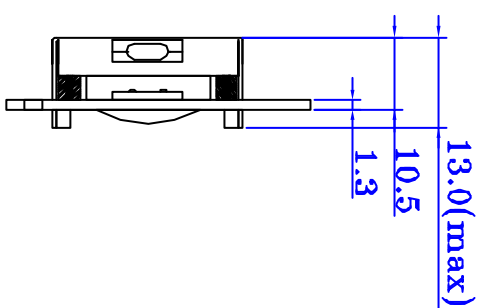

Display Pattern

NOTE:
UNLESS OTHERWISE SPECIFIED STANDARD TOLERANCE $\pm 0.3\text{mm}$.

FEATURE

- 1.122x32 DOTS GRAPHIC LCD MODULE
- 2.BUILT-IN CONTROLLER(ST79820)
- 3.5.0V POWER SUPPLY
- 4.STN;1/32 DUTY CYCLE

PIN	SYMBOL	FUNCTION
1	V _{SS}	POWER SUPPLY (GND)
2	V _{DD}	POWER SUPPLY (+5V)
3	V _O	POWER SUPPLY FOR LCD DRIVING
4	RS	H/L REGISTER SELECT SIGNAL
5	R/W	H/L READ/WRITE SIGNAL
6	E	H/L ENABLE SIGNAL
7	DB0	DATA BUS LINE
8	DB1	
9	DB2	
10	DB3	
11	DB4	
12	DB5	POWER SUPPLY LED+
13	DB6	
14	DB7	
15	LED+	
16	LED-	
17	V _{SS}	POWER SUPPLY (GND)
18	V _{DD}	POWER SUPPLY (+5V)
19	V _O	POWER SUPPLY FOR LCD DRIVING
20	K	H/L ENABLE SIGNAL
21	R/W	H/L READ/WRITE SIGNAL
22	RS	H/L REGISTER SELECT SIGNAL
23	LED+	POWER SUPPLY LED+
24	LED-	POWER SUPPLY LED-

项目	姓名	日期
制图	李旭东	06/5/6
审核	王勇强	06/5/6
批准	张军	06/5/6
单位	mm	
比例	1:1	
版本	A/1	

型号	SG12232Z-LCM
客户型号	



西安海晶光电科技有限公司
SMARTDISPLAYS (XI'AN) CO., LTD